

# 1600-1700 series

Toggle switches • metal lever



## DISTINCTIVE FEATURES

Reduced behind-panel space requirement (models with side terminals)

Optional insulated lever

Wiping contacts



## ELECTRICAL SPECIFICATIONS

- Max. current/voltage rating with resistive load : 4 A 30 VDC
- Initial contact resistance : 10 m $\Omega$  max.
- Insulation resistance : 1,000 M $\Omega$  min. at 500 VDC
- Dielectric strength :  
2,000 Vrms 50 Hz min. between terminals,  
2,000 Vrms 50 Hz min. between poles and between terminals and lever
- Electrical life : 10,000 cycles at full load



## GENERAL SPECIFICATIONS

- Torque : 1.50 Nm (1.10 Ft.lb) max. applied to nut
- Panel thickness : 5 mm (.196) max.
- Operating temperature : -20 °C to +55 °C (-4 °F to +131 °F)



## MATERIALS

- Case : phenolic resin
  - Actuator :  
1600 models : brass nickel plated  
1700 models : polyamide
  - Bushing : brass, nickel plated
  - Contacts : phosphor bronze and brass, silver plated.
- APEM products may be recycled at end-of-life for the re-claiming of valuable metal components.



# 1600-1700 series

Toggle switches • metal lever



## PANEL CUT-OUT

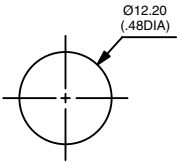

## ELECTRICAL FUNCTIONS

→ KEYWAY

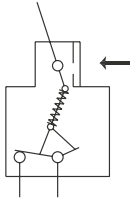

## TERMINALS

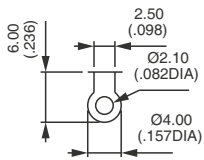

Solder lug

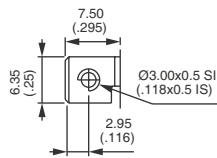

Screw

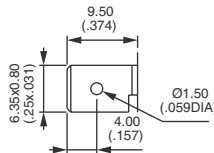

Quick-connect



## ABOUT THIS SERIES

- Sealing boots** are available on models 1600 to protect the switches against dust and water. See "Sealing boots" section of website.
- Mounting accessories** : standard hardware supplied with all models : 1 hex nut U42 and 1 knurled nut U411. It is presented in the "Hardware" section of website.

# 1600-1700 series

Toggle switches • metal lever

## HORIZONTAL SOLDER LUG TERMINALS



Metal lever	Insulated black lever	I	II
1601	1701	ON - OFF	
1606	1706	ON - ON	

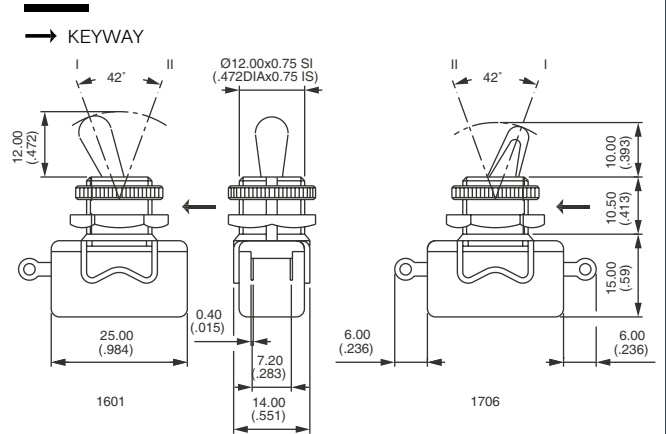

## METAL LEVER VERTICAL SOLDER LUG TERMINALS



	I	II
1611	ON - OFF	
1616	ON - ON	

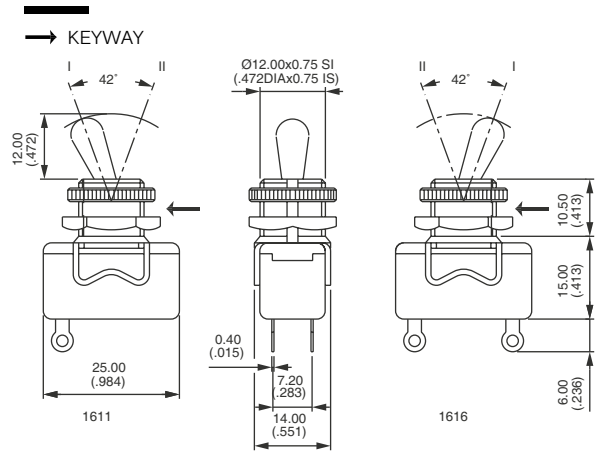

## METAL LEVER HORIZONTAL SCREW TERMINALS



	I	II
1621	ON - OFF	
1626	ON - ON	

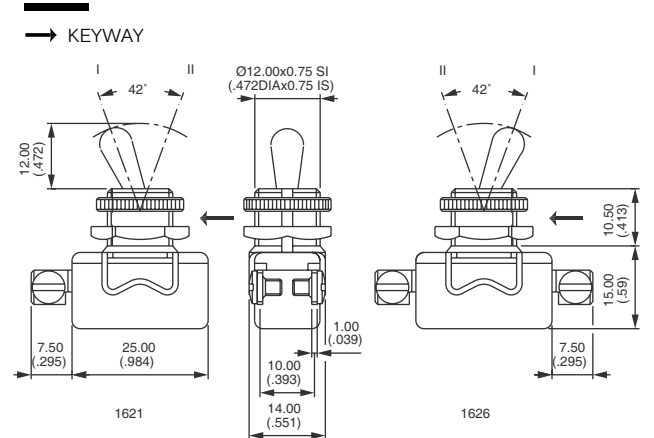

## METAL LEVER HORIZONTAL QUICK-CONNECT TERMINALS



	I	II
1631	ON - OFF	
1636	ON - ON	

